



ARTPLASTICS

Innovative Plumbing Fittings

Roof Rinse Valve

Rinse away the contaminated water from your roof before filling your tank with crystal clear water.

The 'Roof Rinse Valve' is designed to discard the 6 to 10 litres of rainwater flow thereby discarding the most contaminated water off your roof before it reaches your tank.

Incorporate both The Roof Rinse Valve and The Boot Rain Water Head into your rain water collection system to ensure hassle free rain water collection.





Art Plastics

134 Gilba Road Girraween, NSW 2145

Email: sales@artplastics.com.au

Website: www.artplastics.com.au

Phone: 02 9896 7760

Fax: 02 9636 2498

Roof Rinse Valve

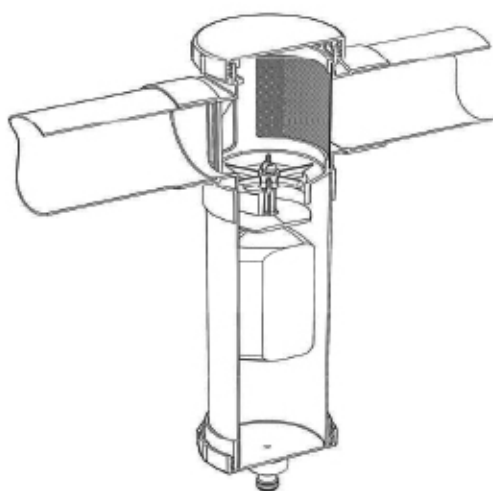

Features include

- ✓ Capture cleaner rainwater by discarding the first flow from your roof and gutters.
- ✓ Simple action, improved float design.
- ✓ Mozzie proof debris filter.
- ✓ Improved bypass action reduces harmonic cycling of float.
- ✓ Automatic reset - ready to rinse your roof each time it rains.
- ✓ Option to utilize increased rinse water. Use a 60 litre slave tank - see our website for instructions.
- ✓ Fits 90mm Stormwater.

CONTACT US

■ New South Wales & Victoria

Art Plastics

Phone: 02 9896 7760

Fax: 02 9636 2498

New South Wales

Colin Jay

Phone: 0400 080 591

Victoria

Andrew Molenaar

Phone: 0438 665 444

■ South Australia

Impressions Bathroomware

Phone: 08 8352 8600

Fax: 08 8352 8622

■ Western Australia

Pride Industries

Phone: 08 9272 6511

Fax: 08 9272 3427

■ Queensland & NT

Collis Marketing Services

Phone: 07 3805 6664

Fax: 07 3805 6668

■ Tasmania

Wholesale Products

Phone: 03 6273 3455

Fax: 03 6273 1901